



RoofSafe Anchors, with
Force Management technology
for Bituminous, Mineral Felt and
other Membrane Roof Systems



RoofSafe Anchors, with Force Management technology for bituminous, mineral felt and other membrane roof systems



contents

working safely at heights	02
force management systems	03
anchor installation	03
structural validation	04
anchor construction	04
installation detail	05
green roof systems	05
system design parameters	05
performance tested	06
system integration	06

for more information about our range of equipment visit our website at www.unilinesafety.com

working safely at heights

Roof work can be a hazardous and high risk activity. The risks can be mitigated and effectively controlled by using a fall protection system in conjunction with management controls and training.

Uniline Safety Systems are experts in their field and provide sound advice to assist you in making a well informed safety decision that will reduce the chances of avoidable workplace accidents.

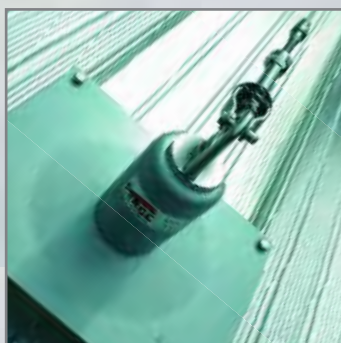

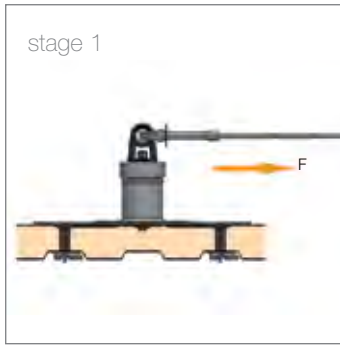

pre-activation technical drawing

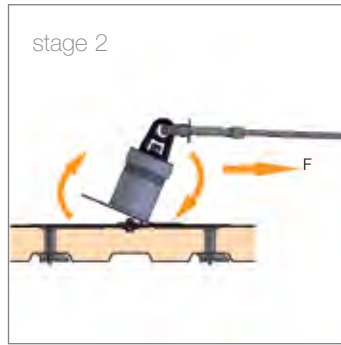

activation technical drawing

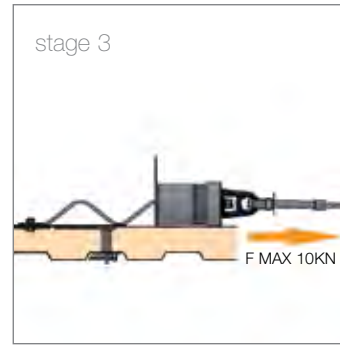

post-activation technical drawing

how it works

Uniline's technically superior RoofSafe Anchors permit many metal decks, plywood and concrete roof constructions to be used as structural anchors, by limiting the forces that are generated in the event of a fall to less than 10kN through a built in energy absorber.

Built in energy absorbing elements are particularly beneficial in 'top fix' safety anchors as they enable energy to be absorbed throughout the entire fall protection system. This is especially important in short systems and systems with corners, as loads in these cases can be very high and beyond the tolerance of the roof system. Roof anchors which do not incorporate energy absorbing elements, have limited use as anchor devices on metal roof systems.

The reaction of the RoofSafe Anchor in the event of a fall re-orientates the load to a more beneficial plane for the roof structure, before deployment of the energy absorber reduces the fall energy and distributes the load through the fixings, ensuring the safe arrest of the worker, or workers.

03

bituminous, mineral felt membrane and roof systems

anchor installation

The anchor can be fitted to metal decking, plywood or concrete roof constructions from the top of the roof using M8 toggle clamps, mechanical fixings or stud, provided with anti-compression spacers. The length of the toggle bolt can be increased to allow for use in constructions with deep insulation. The number and size of the toggle clamps/stud have been calculated to counter the overturning moment applied by the anchor in the first stage of activation and resist the shear load in the second stage of activation when the energy absorber deploys. When using stud and chemical resin to secure the anchor, it is important to follow the manufacturers specification and installation guidance.



toggle clamps



top fix solution



quick and easy installation

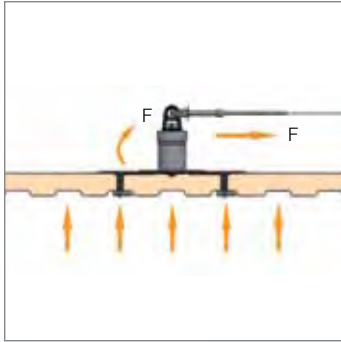

uplift forces technical drawing

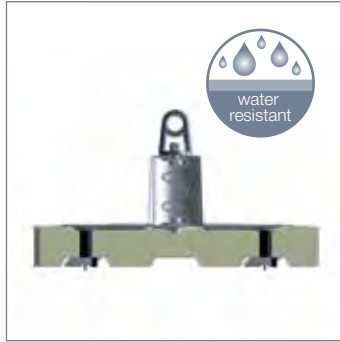

force management anchor cross section

structural validation

RoofSafe Anchors can only be installed on roof systems that have been validated as capable of supporting the distributed loads applied in the event of a fall. Uniline offer alternative solutions for roofs which are not suitable.

This predictable distributed load can be used to validate the roof systems suitability for use as a structural anchor. In the case of built up flat roofing systems, the distributed load can vary depending upon the depth of the insulation and can range from 0.5kN/sq,m to 4.0kN/sq,m where insulation is 300mm deep.

anchor construction

Anchors are constructed from mild steel and have a protective corrosion resistant coating. The roof membrane can be bonded directly to the base plates and casing thereby providing a neat waterproofing detail, or alternatively, for Mineral Felt Roofs, Uniline can provide a pre-engineered weather proofing detail to simplify the waterproofing process and ensure the anchor has long term resistance to water ingress.

Only approved waterproofing details should be used and detailing work must be carried out by an authorised roofing contractor. Base plates are completely flat to make sealing easier and have recessed fixing points to protect the roof membrane from becoming damaged.

Very importantly, no elements of the anchor are exposed to the environment after installation, ensuring long-term corrosion resistance and anchor performance.



04

Integrating Uniline's cable safety systems into your building is made easy and trouble free with Uniline's range of patented RoofSafe Anchors with Force Management technology.

The design of the anchor is neat and unobtrusive, limiting any visual impact to the building.

type of roof this anchor can be used on:

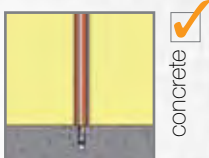

concrete

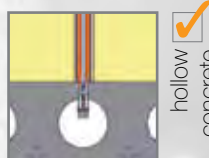

hollow concrete

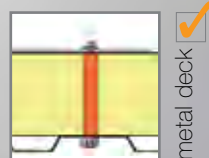

metal deck

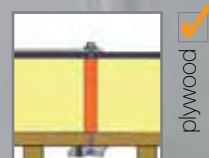

plywood

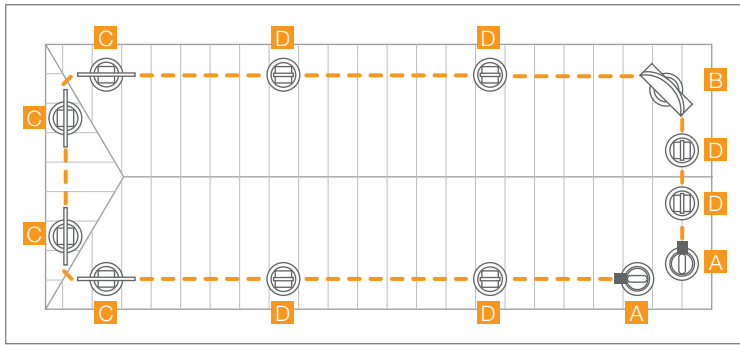

system configuration technical drawing



typical installation detail

The anchors shown above are used for integrating Uniline's cable fall protection systems on to your building, thereby facilitating safe access.

- Type A: End Anchors
- Type B: Corner Anchors
- Type C: Variable Anchors
- Type D: Intermediate Anchors

The Type D anchor may also be used as a single point anchor. (EN795 class A2).

Due to the very large number of roof profiles available in the market place, Uniline carries a wide range of standard stock sizes and can also produce special sizes on request and following validation of the roofing system.

For further information, please contact Uniline's Technical Department.

green roof systems

Use of Uniline's pre-engineered weather proofing detail enables the anchor to be used in conjunction with Green Roofing Systems.

The sedum element of the roof construction can be installed around the anchor without any fear of water penetration through the sealing detail.

system design parameters

RoofSafe Anchors can be used with RoofSafe Cable systems to provide cost effective and functional safety access solutions.

Design requirements for the anchors are;

RoofSafe Cable: 12m maximum span (systems less than 12m must have at least one intermediate anchor).

RoofSafe Cable provides continuous hands free access for the user of the system.

System designs must be calculated using Uniline for Windows software in order to ensure that the proposed

layout can support the number of workers intended to use the system in the future. Furthermore the software will advise on the ground clearance required beneath the work area in order to safely arrest a fall.

Uniline provide technical drawings and specification details to help Architects and Building Safety Engineer's with the inclusion of its products in building specification documents and tenders, no matter how complex your requirements may appear. Local design support can be provided by our network of System Integration Specialists.



green roof system



RoofSafe cable



RoofSafe cable



installer training



testing the system

performance tested

RoofSafe Anchors are tested to exceed the standards of EN795, are CE marked and come with a 10 Year Guarantee for performance and corrosion resistance. (Subject to terms and conditions).

For your peace of mind Uniline operates an ongoing policy of testing on 'as built' roof constructions and has achieved approvals from many manufacturers of roof system.

system integration

RoofSafe Anchors and Cable systems should only be designed and fitted by companies and personnel authorised and trained to do so.

Uniline operates a training programme for its installation personnel to ensure competence. Installation technicians carry a competence record showing that they have been trained in the correct installation techniques required for our products.

Uniline operates this system for your peace of mind and the safety of the people that will use our products in the future. It is an integral part of our ISO9001:2000 quality system and ensures high standards are maintained.

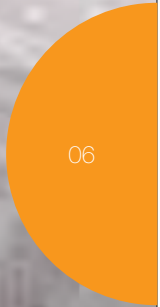

Uniline Safety Systems is a leading international manufacturer of fall protection products and systems. Through a combination of expert knowledge and practical experience, we can help our customers reduce risk and increase safety when working at height.

Uniline's comprehensive range of products offers fully compliant, practical solutions for structures of all types, in all industries. Our ethos of delivering quality, service, training and support for our customers has earned Uniline a deserved reputation for excellence around the world.

Operating through specialist safety companies in over 25 countries, Uniline provides local support and installation services to meet the specific safety objectives of all our customers.



If you need a safety solution for roof access during maintenance and inspection tasks, then look no further than Uniline's RoofSafe product range. Our products, including roof anchors, horizontal lifelines, horizontal rail systems and walkways offer comprehensive protection for workers on all types of roofs.



MultiSafe comprises three of the best known brands in fall protection safety: Uni-8, Uni-16, and UniRail. The versatility of these products combined with Uniline's expertise in fall protection ensures we can solve even the most complex of height safety problems in industry, construction, façade access and for all manner of building maintenance and inspection tasks.



The best vertical fall protection systems in the world won't let you down. The extensive development of the EasyClimber range of products for vertical structures including masts, towers, pylons, wind turbines, silos, bridges and chimney stacks ensures customers will enjoy the safest and most functional climbing experience possible.



A range of intuitive rescue and access products to aid recovery of workers after a fall or in an emergency at height. The diversity of Uniline's Rescue range ensures we can provide a solution for all types of rescue situations whilst keeping safety the top priority.



because lives depend on it

www.unilinesafety.com

local distributor/systems integrator

ROPE ACCESS / RIGGING / HEIGHT SAFETY

RIGCOM
ACCESS

www.rigcomaccess.com

PO BOX 730
North Sydney
NSW 2059

Tel: +61 2 9966 1673
admin@rigcomaccess.com

Uniline Safety Systems Limited

UK
5a Merse Road
North Moons Moat
Redditch, Worcestershire
B98 9HL

t: +44 (0) 1527 548 000
f: +44 (0) 1527 591 000

USA
17200 Chenal Parkway
Suite #352
Little Rock, AR 72223
USA

t: +01 (501) 517 6056
f: +01 (501) 325 3477

AUSTRALIA
P.O. Box 1226
Surfers Paradise
Queensland 4217
Australia

t: +61 (7) 5539 0164
f: +61 (7) 5570 4208

SPAIN
C/Albaracin 6-3D
11300 La Linea
Cadiz
España

t: +34 (856) 125 173
m: +34 (627) 902 606